

TECHNICAL MANUAL

OPERATOR'S, UNIT AND
DIRECT SUPPORT MAINTENANCE MANUAL
(INCLUDING REPAIR PARTS AND SPECIAL TOOLS LIST)
FOR

SARGENT-WELCH
VACUUM PUMP

THIS TECHNICAL MANUAL IS AN AUTHENTICATION OF THE MANUFACTURER'S COMMERCIAL LITERATURE AND DOES NOT CONFORM WITH THE FORMAT AND THE CONTENT REQUIREMENTS NORMALLY ASSOCIATED WITH ARMY TECHNICAL MANUALS THIS TECHNICAL MANUAL DOES, HOWEVER, CONTAIN ALL ESSENTIAL INFORMATION REQUIRED TO OPERATE AND MAINTAIN THE EQUIPMENT

Approved for public release; distribution is unlimited.

HEADQUARTERS, DEPARTMENT OF THE ARMY
28 SEPTEMBER 1990

THIS TECHNICAL MANUAL IS AN AUTHENTICATION OF THE MANUFACTURER'S COMMERCIAL LITERATURE AND DOES NOT CONFORM WITH THE FORMAT AND THE CONTENT REQUIREMENTS NORMALLY ASSOCIATED WITH ARMY TECHNICAL MANUALS THIS TECHNICAL MANUAL DOES, HOWEVER, CONTAIN ALL ESSENTIAL INFORMATION REQUIRED TO OPERATE AND MAINTAIN THE EQUIPMENT.

Approved for public release; distribution is unlimited.

SUPPLEMENTARY INTRODUCTORY MATERIAL

1-1 Maintenance Forms and Records

Department of the Army forms and procedures used for equipment maintenance will be those described by DA Pam 738-750, The Army Maintenance Management System.

1-2. Reporting Errors and Recommending Improvements.

You can help improve this manual. If you find any mistakes or If you know of a way to Improve the procedures, please let us know. Mail your letters, DA Form 2028 (Recommended Changes to Publications and Blank Forms), or DA Form 2028-2 located In the back of this manual, directly to: Commander, U S Army Troop Support Command, ATTN: AMSTR-MCTS, 4300 Goodfellow Blvd, St Louis, MO 63120-1798. A reply will be furnished to you

1-3. Destruction of Army Material to Prevent Enemy Use.

Refer to TM 750-244-3 for instructions covering the destruction of Army Material to prevent enemy use

1-4. Administrative Storage of Equipment

a. Placement of equipment In administrative storage should be for short periods of time when a shortage of maintenance effort exists Items should be In mission readiness within 24 hours or within the time factors as determined by the directing authority. During the storage period appropriate maintenance records will be kept.

b Before placing equipment In administrative storage, current preventive maintenance checks and services should be completed Shortcomings and deficiencies should be corrected, and all modification work orders (MWO's) should be applied

c Storage site selection. Inside storage is preferred for Items selected for administrative storage. If ns-de storage is not available, trucks, vans, conex containers and other containers may be used

i/(ii Blank)

**Installation
Operation
Maintenance
Parts list
Accessories**

owner's manual

Model 1405 vacuum pump

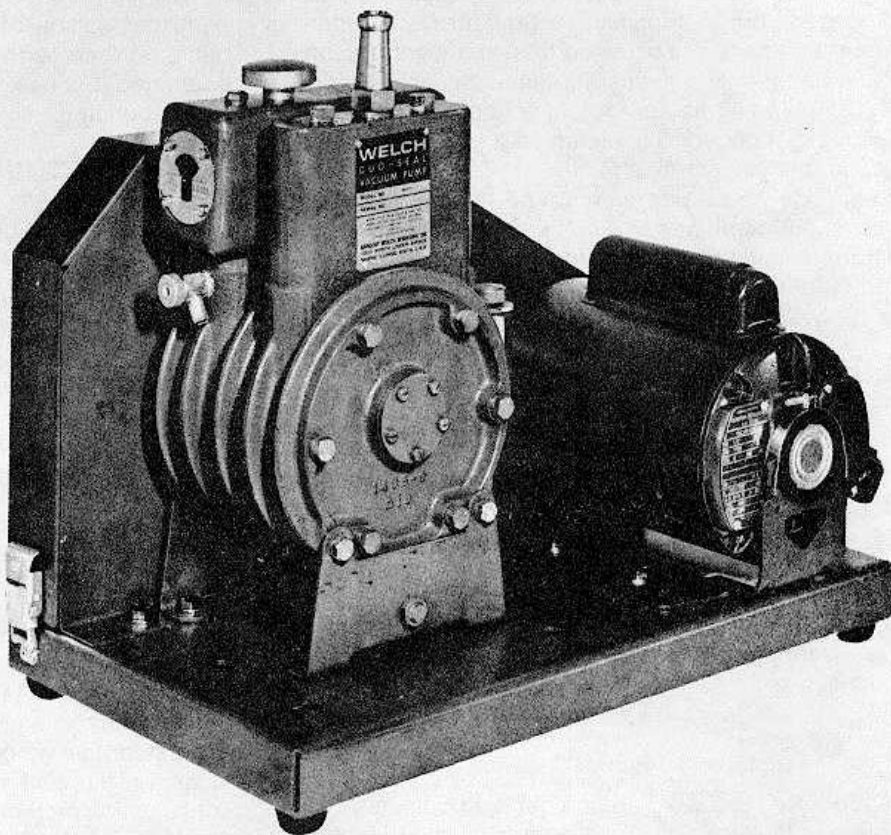

Exchange Service

7300 North Linder Avenue
Skokie, Illinois 60077
(312) 677-0600

1617 East Ball Road
Anaheim, California 92803
(714) 772-3550

35 Stern Avenue
Springfield, New Jersey 07081
(201) 376-7050



SARGENT-WELCH

SCIENTIFIC COMPANY

VACUUM PRODUCTS DIVISION

GENERAL OFFICES 7300 N. LINDER AVENUE
SKOKIE, ILLINOIS 60077; PHONE: 312 677-0600

I. INSTALLATION

H. INTRODUCTION

This manual has been compiled not only for the care and maintenance of the DuoSeal pump now in your possession but as a helpful reference and guide for many problems which are usually associated with mechanical vacuum pumps. Take time to read these Instructions carefully and preserve this manual for future reference, we think it will be useful to you.

I-2. UNPACKING

Carefully remove the pump from the shipping case and unfasten and remove the wooden skid. Preserve all paper work and inspection tags for future reference. If damage has occurred from shipment a claim must be filed with the carrier immediately, preserve the shipping container for inspection by the carrier. If you are required to communicate with your dealer or with the Sargent-Welch Scientific Company be sure to include your order number and the pump model and serial numbers for quick identification. Do not return the pump to the factory without first obtaining shipping Instructions from us.

I-3. PUMP MOUNTING

I-3a. Mounted Pumps

Rubber bumpers are supplied with most of our mounted pumps, either loosely or attached. Bumpers are excellent for applications involving a semi-flexible surface such as a bench top, they help to isolate and eliminate chattering. For more aged requirements the pump base may be bolted directly to a firm foundation with or without the bumpers. All DuoSeal pumps should be mounted in a horizontal plane.

I-3b. Unmounted Pumps

If you have purchased an unmounted pump, refer to Parts list for information concerning the size of motor, motor pulley and belt necessary to drive your particular pump at the recommended speed.

I-4. PUMP LOCATION

The pump should be located preferably in a clean and well ventilated area and adequate space should be provided wherever possible for routine maintenance such as changes of oil and belt adjustment and replacements. Above all, the pump should be located as closely as possible to the bits system in order to utilize it most efficiently. Its location should include such determining factors as the length and size of connections, the number of bends and the type of exhaust connections.

I-5. EXHAUST PROVISIONS

Exhaust connections will be determined by the type of system to be exhausted and the desired cleanliness of the atmosphere surrounding the pump. Under normal conditions of mild evacuations no thing more than the dust cap will be necessary to cover the port. Where relatively high gas flows are involved or where the presence of oil vapor is objectionable an exhaust filter may be fastened to the exhaust port in place of the dust cap. The exhaust filters used on our pumps are capable of absorbing and restricting any vapor particle larger than 0.1 micron. Exhaust filters of this type are designed to pass no more than 21 parts per million of vapor particles larger than 0.1 micron. Where extreme exhaust conditions are encountered it is best to pipe the exhaust directly out of the building.

I-6. ELECTRICAL POWER I-6a. Power Source Review

Review the power source and the motor rating to be sure they agree in voltage, phase and frequency. On three-phase applications the direction of rotation of the motor must be considered. Make a momentary check of rotation at the time of power installation and wiring. Momentary backward rotation of the pump is not harmful. Check the drawings in Parts list for proper direction of rotation.

I-6b. Overload Protection

Motor thermal overload protection is made available by the motor manufacturer as an aid to minimizing motor failure. Overload protection is not a standard feature on all motors, its presence is determined by power requirements and availability. Motors of 1 1/2 horsepower or larger supplied with Sargent-Welch pumps contain no overload protection. Installations of such equipment must comply with local electrical codes which dictate appropriate starter and protect-on devices. Motors of one horsepower or less generally will have some form of overload protection, depending upon availability. Some motors may be protected by manual reset while others will have automatic overload protection. It is strongly suggested that you familiarize yourself with the protect-on supplied with your motor so that you may react accordingly in the event of an emergency. Automatic reset protection is designed to reset itself after a predetermined cooling period. If the fault to the drive remains unaltered, the motor will cycle on and off until the fault is corrected. Manual reset overload protectors prevent the motor from becoming energized until reset by hand. A red reset button protrudes from the motor shell or end shield. The motor data plate will indicate the presence of thermal protection.

I-7. VACUUM CONNECTIONS

I-7a. Choice of Connections

The choice of connections and fittings can have a very marked effect on the pumping speed at the vacuum chamber. Any connection placed between the pump and the chamber creates an impedance to the flow of gas. This is particularly true at low pressures. In the millitorr range where the gas flow is substantially molecular in character, the gas flow is then dependent upon the kinetic activity of the molecules to bring it to the intake of the pump.

I-7b. The Effects of Conductance

It has been shown that the conductance of a tube is proportional to the cube of its diameter and inversely proportional to its length. Therefore, it is imperative that the connecting lines be as large in diameter and as short in length as practical. For best results, the diameter of the connecting tube should be at least as large as the diameter of the pump intake. To avoid a large reduction in pumping speed at the vacuum chamber, it is clear that the conductance of the line must be considerably greater than the speed of the pump.

I-7c. Metal Joints

If metal piping or tubing is used, it is preferable to solder or braze all the connections. Where threaded joints must be used, coat the threads with Glyptal, LocTite Thread Sealant with Teflon, or Leak Lock and screw together tightly. Flanged connections with elastomer gaskets make excellent demountable joints.

I-7d. Glass Joints

Where glass tubing is used between the system and the pump intake, joints can be made by butting the ends of the two sections together in a short section of rubber vacuum hose. This type of joint can also be used with metal-to-metal and glass-to-metal tubing. Worm-screw band clamps are useful for securing the hose to the tubing. Whatever the joint you choose to use, cleanliness should be of utmost importance.

I-7e. Valves and Stopcocks

Metal valves or glass stopcocks may be used in the connecting line between the system and the pump to provide a means of isolating the pump from the system. To minimize the impedance of flow, the valve openings should be as large as possible. Lubricate the rotating plug of the stopcock with a film of vacuum grease sufficiently thick enough to prevent seizure.

I-8. VACUUM GAUGES

The type of vacuum gauge to be used is determined largely by the pressure range to be measured. Pressures in the ranges produced by DuoSeal pumps can be covered by McLeod, Thermistor, Grant or Thermocouple gauges. The McLeod gauge is used where high accuracy of measurement is required. The Pirani, Thermistor and Thermocouple gauges are electrical and give continuous readings of the total pressure. They are preferred where rapid pressure changes occur. The McLeod gauge does not measure condensable vapors; therefore, if vapors are present it will generally read lower in pressure than electrical gauges. For higher vacuums in systems employing diffusion turbo-molecular or ion pumps, the hot filament ionization of the Philips gauge is used.

I-9. TRAPS

I-9a. The Need for a Trap

Where corrosive vapors or large quantities of condensable vapors are evolved from vacuum processing, a cold trap may be used in the connecting line to the pump. It will help prevent damage to the pump mechanism and reduce oil contamination. The cold trap, immersed in a suitable Dewar flask, is installed so that the vapors may come in contact with the surfaces of the trap and condense. Commonly used refrigerants are liquid nitrogen or dry ice and acetone. The refrigerant to be used depends upon the freezing point of the contaminants. A variety of glass cold traps and Dewar flasks are available from Sargent-Welch.

I-9b. The Care of a Trap

When using a cold trap, the refrigerant should be maintained at a high level in the flask to keep the trap at a uniformly low temperature. If the trap is rewarmed, it may allow re-evaporation of the condensate. The opening of the Dewar flask should not be obstructed as the refrigerant boil-off can produce dangerously high pressures. If the trap becomes saturated, it should be disconnected from the system, drained and cleaned. An increase in pressure in the vacuum system will normally indicate that the trap has become saturated. To clean the trap, remove the refrigerant and allow the trap to warm up. Remove the trap from the system and arise off the condensate with a suitable solvent. Thoroughly clean and dry the trap before pre-installing in the system.

I-10. TYPES OF LUBRICANTS

All Sargent-Welch mechanical vacuum pumps are normally tested with DuoSeal oil and chipped with a full

charge to prevent unnecessary contamination. An additional supply of oil is furnished with each pump with instructions to drain and discard the oil contained in the pump and replace with the fresh DuoSeal oil. DuoSeal oil has been especially prepared and is ideally suited for use in mechanical vacuum pumps because of its desirable viscosity, low vapor pressure and chemical stability. The vacuum guarantee on all Sargent-Welch pumps applies only when DuoSeal oil is used. Other lubricants for special applications are available including venous lubricants for oxygen compatibility lubricants for use with diffusion pumps as well as other special requirements.

II. OPERATION

II-1. STARTING PROCEDURES

II-1a. Starting a DuoSeal Pump

Before attaching the pump to a system it is well to familiarize yourself with the function and action of the pump which you have now acquired. Remove the intake and exhaust port plugs and temporarily provide a stopper for the intake and a dust cap for the exhaust. Review the power requirements as described in Paragraph 1-6.

II-1b. Cleanliness

Take every precaution to prevent foreign particles from entering the pump. A fine mesh screen is provided for this purpose in the intake passage of all the DuoSeal pumps.

II-1c. Oil Level Determination

The amount of oil suitable for efficient and satisfactory performance should be determined after the pump has reached its operating temperature. Initially, however, the pump should be filled with fresh oil while the pump is idle. Fill the pump until the oil level falls between the two oil level marks. If after a short period of operation the level should fall, it is likely the result of oil entering some of the interior pockets of the pump. If a gurgling sound occurs, additional oil must be added. In general, the oil level will be higher during high pressure operation. Mechanical pumps will gurgle in varying degrees under four conditions of performance. [a] when operating at high pressure as in the beginning cycles of evacuation of a chamber, [b] when the oil level in the pump reservoir is lower than required, [c] when a large leak is present in the system; and [d] when the vented exhaust valve is open. Awareness of these possibilities will save time in setting up a system. Best performance of a mechanical pump is generally obtained after sufficient time has been allowed for the pump to come to operating temperature.

II-2. LEAK DETECTION

II-2a. Large Leaks

The importance of eliminating all leaks in a vacuum system is obvious when it is realized that a leak into the system, at atmospheric pressure, expands in volume by a factor of 750,000 to 10,000,000 or more. The pump must remove this added volume to maintain the desired vacuum. Fortunately a number of effective techniques for leak detection have been developed. Large leaks can be located by pressurizing the system and painting the suspected area with a thick soap solution. Escaping air will produce soap bubbles.

II-2b. Small Leaks

Small leaks in glass systems may be located by probing with a high frequency coil of the Tesla type. This instrument is an ungrounded, high-potential spark coil with a pointed electrode. The discharge spark from the coil will seek and pass through any minute opening and produce a faint pink glow at the location of the hole. In using a Tesla coil, the electrode point should be held about 1/2 inch from the glass and should be kept in constant motion. It is not recommended for use in very thin-walled systems or in locations adjacent to glass-to-metal seals. Small leaks may also be detected by spraying a suspected area with acetone or gases rich in hydrogen, and observing a sudden change in pressure on an electrical gauge. The difference in calibration of these gauges, for air and other gases, will produce a distinct change in the pressure reading. To use this method of detection, the system must be under vacuum and the gauge sensing tube must be located between the pump and the area to be probed. Use extreme caution, as these materials are highly flammable!

II-2c. Fine Leaks

Locating very fine leaks requires a helium-sensitive, mass-spectrometer leak detector. This Instrument will locate leaks which cannot be detected by any other method Numerous fine leaks can have the total effect of a large leak.

II-3. SHUTDOWN PROCEDURES**II-3a. DuoSeal Shutdown**

A few simple precautions are all that is necessary when a shutdown is in order If a gauge is connected to the system, first isolate the gauge, then turn off the power and open the system to atmosphere If the pump is removed from the system, cover the intake port with a rubber stopper or suitable cover to protect the pump against contamination and loose particles If the pump has been contaminated in service and is going to be shelved for a prolonged period it is best to drain the oil and refill with a fresh charge.

II-4. THE PRINCIPLE OF VENTED EXHAUST**II-4a. The Effects of Unwanted Vapors**

Systems which contain undesirable vapors cause difficulty both from the standpoint of attaining desirable ultimate pressures as well as contamination of the lubricating medium A vapor is defined as the gaseous form of any substance which is usually a liquid or a solid Water, oil and mercury vapors are three of the more common vapors encountered in typical vacuum systems When such vapors exist in a system, the vapors or mixtures of gas and vapor are subject to condensation within the pump; the precipitated liquid may thus ultimately dissolve or become emulsified with the lubricating medium This emulsion is re-circulated to the chambers of the pump where it is again volatilized causing increased pressure within the system.

II-4b. The Presence and Removal of Condensate

Condensation takes place particularly in the compression stroke of the backing or second stage of a two-stage pump The compression stroke is that portion of the cycle during which the gas drawn from the intake port is compressed to the pressure necessary to expel it past the exhaust valve Condensation takes place when the ratio between the initial pressure and the end pressure of the compression is high that is, when the mixture of vapor and gas drawn from the intake port is compressed from a low pressure to a high pressure By adding air through the vented exhaust valve to the mixture of vapor and gas being compressed, the pressure required for delivery past the exhaust valve is reached with a considerably smaller reduction of the volume of the mixture, thus, depending upon the amount of air added, condensation of the vapor is either entirely avoided or substantially reduced.

II-4c. Pump Function Without Vented Exhaust

In a pump functioning on a contaminated system and operating without the vented exhaust feature, compression within the stage takes place in the normal manner until the saturation pressure of the contaminating vapor contained with the mixture of gas and vapor is reached The saturation pressure of water vapor is that pressure and corresponding temperature at which the dew point of the vapor is reached and condensation occurs The saturation pressure of water vapor at an ambient temperature of 20°C is 17.5 torr, while at 60°C, the approximate operating temperature of a pump, the saturation pressure is 149 torr The external side of the exhaust valve is subjected to atmospheric pressure Consequently a compressive force somewhat greater than atmospheric pressure is required to open the valve and permit expulsion of the gas Sometime during increased compression of the mixture of gas and vapors, the saturation pressure of 149 torr for the water vapor is reached and the vapor condenses The condensate is then allowed to emulsify with the oil which is re-circulated within the pump stages thus providing continued contamination of the system.

II-4d. Pump Function With Vented Exhaust

On the other hand, when ballast air at atmospheric pressure is supplied to the compression stroke by means of the vented-exhaust valve, the partial pressure of the unwanted vapor becomes a very small part of the total pressure of the mixture of gas, vapor and newly supplied air The vapor is thus prevented from reaching its saturation pressure corresponding to the temperature of the pump and is finally expelled from the pump as a vapor.

II-4e. Controlled Ballast Flow

Some degree of variation in ballast flow may be obtained by the amount of opening applied to the vented-exhaust valve. Two or more turns of the valve are sufficient to open it wide With the valve open,

the sound of the exhaust is similar to that of a pump operating against a large leak. Because of the increased pressure introduced into the compression stroke, the pump must work a little harder to function, thus resulting in an increased operating temperature of approximately 8°C over a prolonged period of time. Tests have shown that continuous and prolonged operation for several weeks under these conditions is not injurious to the pump.

II-4f. Other Forms of Contamination Control

The application of the vented-exhaust valve is a moderate and very successful method for the removal of condensable vapors. For very heavily laden systems, other means of removal such as oil separators may be required. For mild cases of contamination the simple expedient of a cold trap or a change of oil may serve the purpose.

III. MAINTENANCE

III-1. VACUUM PROBLEMS

III-1a. Pressure Determinations

Leakage, contamination and unusual outgassing are the general causes of problems associated with poor vacuum. To operate at maximum efficiency a system must be thoroughly clean. If the system is completely clean and free from leaks, and unwarranted vacuum problems still exist, the pump should be checked. A simple criterion for the condition of a mechanical pump is a determination of its ultimate pressure capability. This can be accomplished by attaching a gauge directly to the pump. The gauge may be any suitable type provided consideration is given to the limitations of the gauge being used. Refer to Paragraph 1-9 for further suggestions. If the pressure is unusually high the pump may be badly contaminated, low on oil or malfunctioning. On the other hand, if the pressure is only slightly higher than the guaranteed pressure of the pump, an oil change may be all that is required.

III-1b. Oil Contamination

The most common cause of a loss in efficiency in a mechanical pump is contamination of oil. It is caused by condensation of vapors and by foreign particles. The undesirable condensate emulsifies with the oil which is recirculated and subjected to re-evaporation during the normal cycle of pump activity thus reducing the ultimate vacuum attainable. Some foreign particles and vapors may form sludges with the oil impair sealing and lubrication and cause eventual seizure. A vented-exhaust valve is helpful in removing vapors, especially water, but it is not equally effective on all foreign substances, therefore, periodic oil changes are necessary to maintain efficient operation of the system. The required frequency of changes will vary with the particular system. Experience with the process will help you determine the normal period of operation before an oil change is required.

III-2. OIL CHANGES AND OIL LEVEL

III-2a. Draining the Pump

An oil change is most easily accomplished when the pump is warm and the oil is less viscous. Use a container large enough for the oil in the particular pump. Stop the pump, and open the drain valve. A thorough job may be accomplished by tipping the pump slightly. If this is possible the small residue remaining in the pump may be forced out by hand-rotating the pump pulley with the exhaust port partially closed and the intake port open. Closing the exhaust port completely under these conditions will create excessive pressure at the drain valve which may cause the oil being drained to splatter.

III-2b. Flushing the Pump

After removing all the oil close the drain and pour about four ounces of clean DuoSeal oil into the intake port. Open the exhaust port and operate the pump for about a minute with the intake port alternately opened and closed to agitate and circulate the fresh oil. Again stop the pump, drain the flushing oil and force out the residue as before. The amount of flushing oil and the number of flushes will be determined by the extent of contamination and the color of the oil. Under no circumstances should anything other than DuoSeal oil be used for flushing a mechanical pump. The higher vapor pressures of other types of oil will cause difficulty later in the attainment of a high vacuum.

III-2c. Refilling the Pump

After you are satisfied that the pump has been thoroughly flushed, refill the pump by pouring new DuoSeal oil into the exhaust port fill to the indicated level and start the pump with the intake closed.

(Continued on page 11)

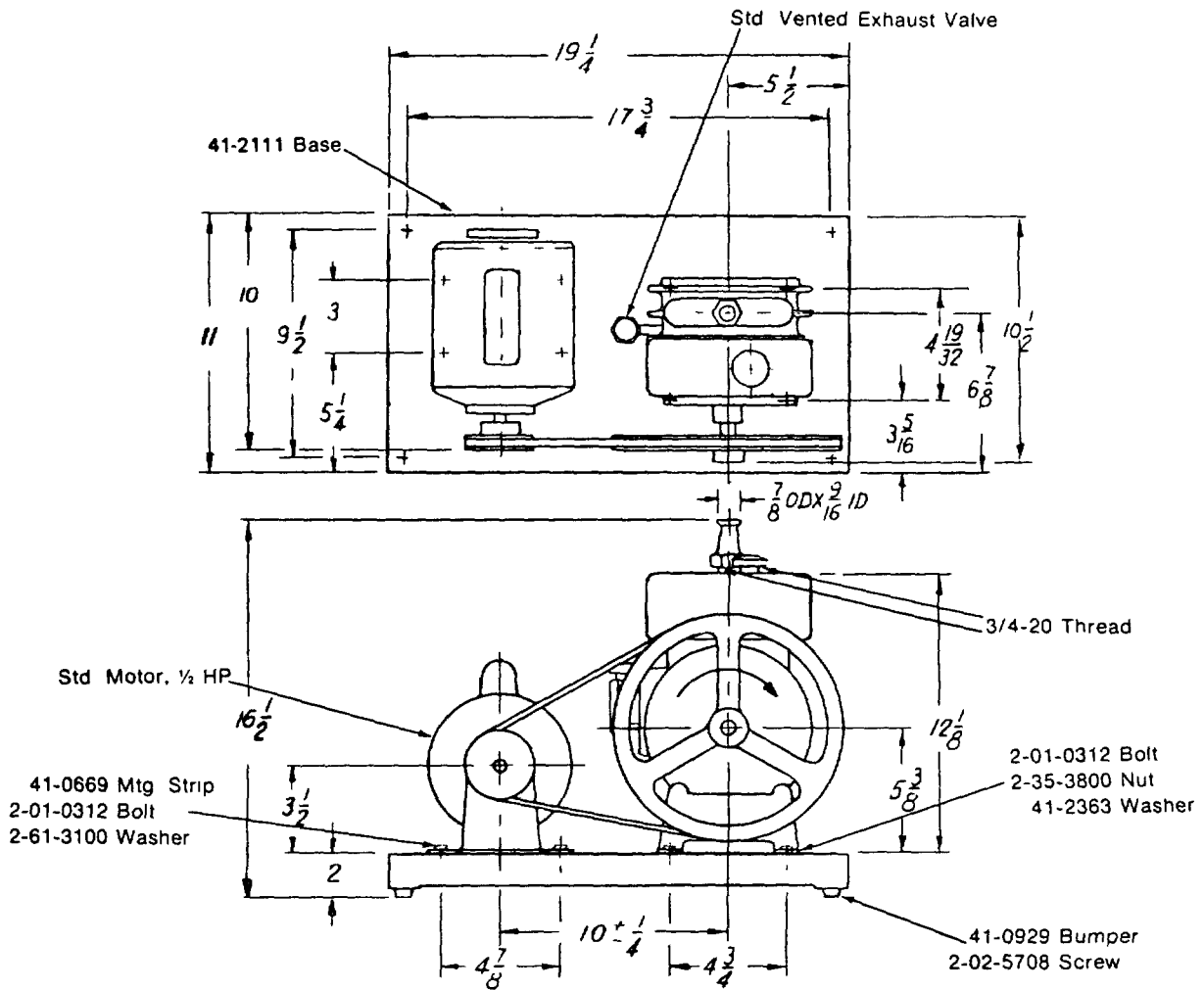

SPECIFICATIONS

Free-Air Displacement. L/M	60
CFM.....	2 1
Guaranteed Partial Pressure	
Blankoff, millitorr	0 1
Pump Rotational Speed. RPM.....	525
Number of Stages	2
Oil Capacity. qts	1/4
Standard Belt Guard (not shown).....	No 1371 G
Net Eight. Pump Oddly. Bibs	58
Net Eight. Mounted Pump. Bibs.....	93
Chipping Eight. Mounted Pump. Bibs.....	106
Option A1 Exhaust filter Complete.....	No 1417
filter Element. Aid Maze	No 1417F
filter Element. Technolab.....	No 1417L
seize of Rubber Stopper for Intake.....	0
Line Cord. with Switch for 115V	No 41 -1058
Line Cord. with Switch for 230V	No 41-1057

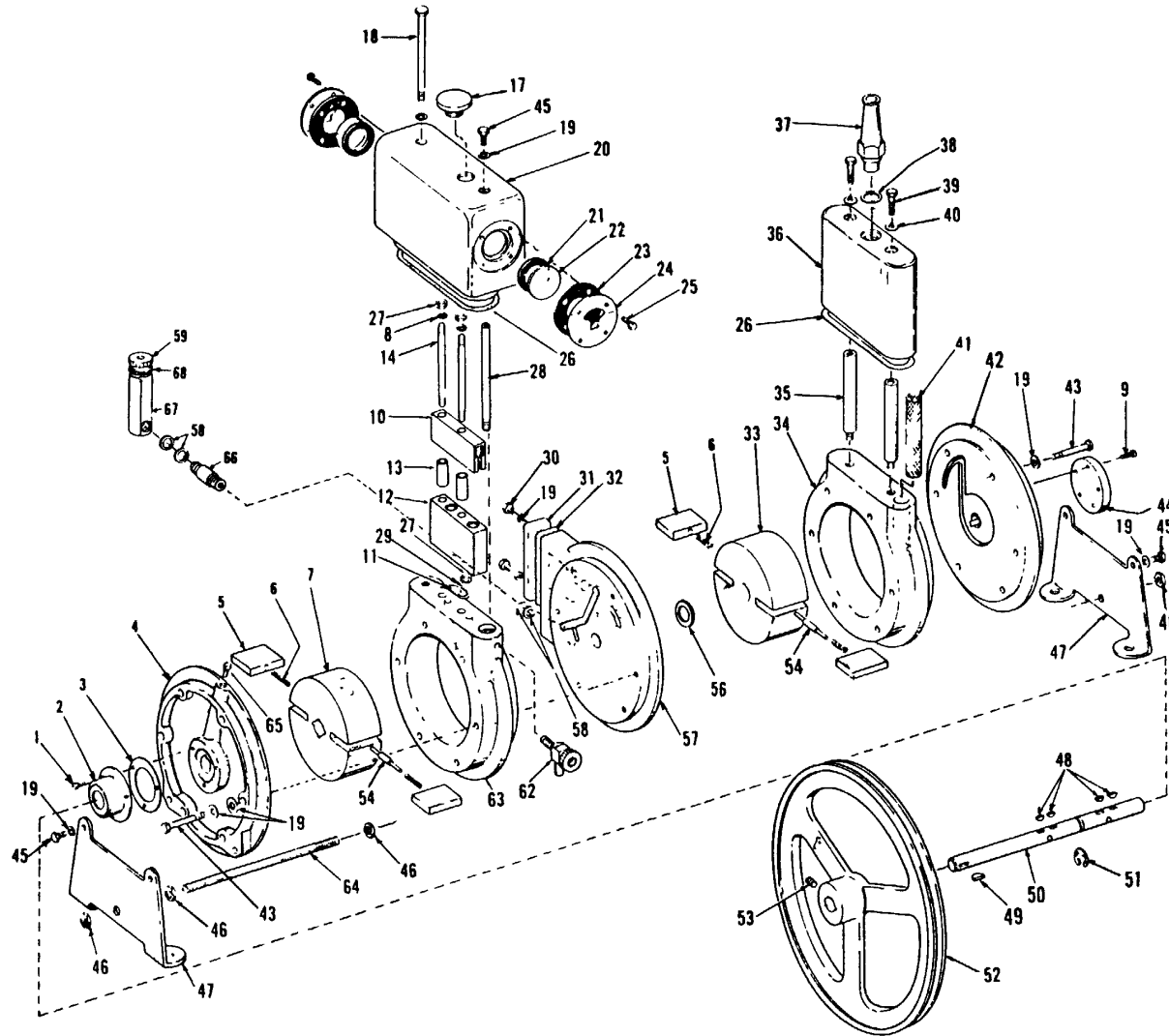

MODEL 1405
VACUUM PRODUCTS DIVISION
SARGENT-WELCH SCIENTIFIC COMPANY
7300 NORTH LINDER AVENUE
SKOKIE, ILLINOIS 60077

PARTS LIST
MODEL 1405 VACUUM PUMP

ITEM	QUANTITY	PC NO.	DESCRIPTION	ITEM	QUANTITY	PC NO.	DESCRIPTION
1	3	2-00-2705	FAIL HD STEEL SCREW 10-32x 5/16	44	1	41-1255	SHAFT END CAP
2	1	1401E	SHAFT SEAL INCLUDING GASKET, ITEM 3	45	5	2-01-0312	HEX STEEL CAP SCREW 5/16-18x 3/4
			AND SCREWS, ITEM 1	46	4	41-0199	HEX NUT
3	1	41-0643	GASKET	47	2	41-1286	LEG
4	1	41-1287	FRONT END PLATE	48	4	41-0613	WOODRUFF KEY
5	4	41-2194	VANE	49	1	41-0624	PULLEY KEY
6	4	41-1304	SPRING	50	1	41-1293	SHAFT
7	1	41-1253	EXHAUST ROTOR	51	1	41-1150	RETAINING RING
8	2	2-65-0000	STEEL SHAKER PROOF LOCKWASHER #10	52	1	41-2194	PULLEY INCLUDING SETSCREW. ITEM 53
			EXT . T	53	1	2-01-9306	SOCKET HD SETSCREW 5/16-18x 3/8
9	5	2-00-2708	FAIL HD STEEL SCREW 10-32x 1/2	54	2	41-1303	SPRING HOLDER
10	1	41-3761	VALVE BLOCK COVER				
11	1	41-1239	VALVE	56	1	41-1285	THRUST WASHER
12	1	41-3762	EXHAUST VALVE BLOCK	57	1	41-1291	CENTER PLATE
13	2	41-3767	SLEEVE	58	4	41-1056	ALUMINUM WASHER
14	2	41-3766	COVER SUPPORT	59	1	41-1736	VENTED EXHAUST VALVE
17	1	41-1345	DUST CAP	62	1	41-1734	DRAIN VALVE
18	1	2-01-0372	HEX STEEL CAPSCREW 5/16-18x 1/2	63	1	41-1298	EXHAUST RING
19	32	41-2363	WASHER	64	1	41-1280	LEG ROD
20	1	41-2084	EXHAUST CHAMBER	65	1	2-01-2106	FAIL HD STEEL SCREW 1/4-20x3/8
21	2	41-1266	TENSION CHAMBER	66	1	41-2350	CONNECTING NIPPLE
22	2	41-1268	GLASS DISK	67	1	41-1745	ADAPTER
23	2	41-1267	RUBBER WASHER	68	1	41-2757	LOCKNUT
24	2	41-1061	OIL WINDOW FRAME				
25	8	2-00-0608	HEX HD STEELSCREW 8-32x 1/2		1	1-99-5282	SEALANT (TUBE)
26	2	41-1308	GASKET, CENTER PLATE				
27	3	2-30-5708	HEX STEEL NUT 10-32x3/8				
28	1	41-3763	ADAPTER ROD				
29	1	2-70-6736	WASHER #105				
30	2	2-01-0310	HEX STEEL CAPSCREW 5/16-18x 5/8				
31	1	41-1275	CENTER PLATE COVER				
32	1	41-1178	GASKET				
33	1	41-1290	INTAKE ROTOR				
34	1	41-2529	INTAKE RING				
35	2	41-1306	EXTENSION ROD				
36	1	41-2080	INTAKE CHAMBER				
37	1	41-1274	NIPPLE				
38	1	41-0409	WASHER				
39	2	41-1305	SPECIAL CAPSCREW				
40	2	41-1165	ALUMINUM WASHER				
41	1	41-0891	AIR FILTER				
42	1	41-1288	INTAKE END PLATE				
43	12	2-01-0344	CAP SCREW 5/16-18x 2-3/4				

Model 1 405 Drive Requirements

		MOTOR					
Cat. No.	Belt Number and Size	Pulley Number and Size	HP V	HZ	PH	RPM	Remarks
1405B	41-07104L415	41-0668 3x 625	41-1907 ½ 115/230	60	1	1725	For 115V
1405C	41 -0710 4L415	41 -0668 3 x 625	41 - 1907 ½ 115/230	60	1	1725	For 230V
1405K-01	COMPLETE GASKET and SEAL KIT						
1405K-02	REPAIR KIT						
1405L-20	41-0713 4L420	41-0667 3.5 x 625	41-1905 ½ 110/220	50	1	1425	
1405M-25	41-0710 4L415	41-0668 3 x 625	41-1904 ½ 230/460	60	3	1725	
1405Q-34	41-0710 4L415	41-0668 3 x.625	41-1911 ½ 115/230	60	1	1725	Totally Enclosed
1405S-35	41 -0713 4L420	41 -0667 3.5 x .625	41 -2824 ½ 110/220	50	1	1425	Totally Enclosed
1405U-39	41-0710 4L415	41-0668 3 x.625	41-1913 ½ 230/460	60	3	1725	Totally Enclosed
1405W-50	41-0710 4L415	41-0668 3x 625	41-1912 ½ 115/230	60	1	1725	Explosion Proof
1405X-55	41-0710 4L420	41-0667 3 5 x 625	41-2825 ½ 110/220	50	1	1425	Explosion Proof
1405Y-60	41 -0710 4L415	41 -0668 3 x 625	41 -2823 ½ 230/460	60	3	1725	Explosion Proof

Note: 1 Pump pulley. No 41-2194. 10' 0 D x 62 5" Bore .is common to all pumps
 2 4L415 Belts. "A" size. ½ "W x 5/16" D. are stamped 1405A

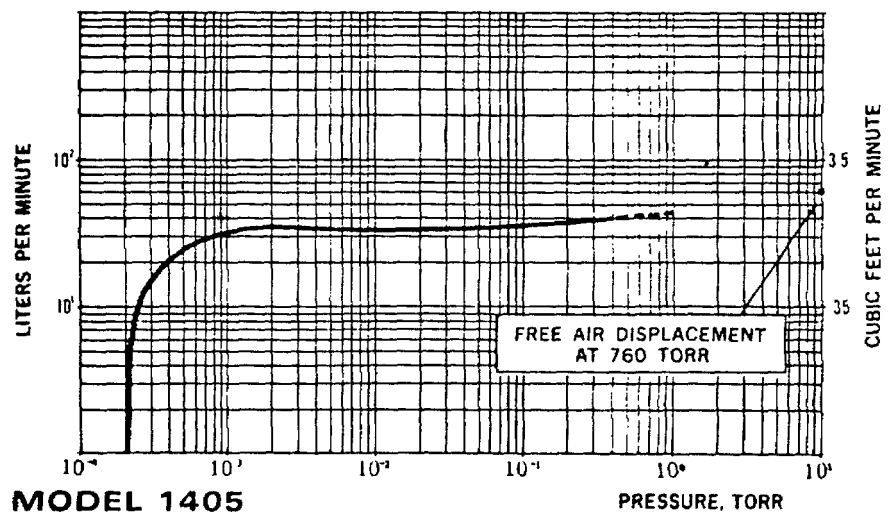

A burbling noise is characteristic when high pressure air is drawn through the pump. It should disappear quickly as the pressure within the pump is reduced. If burbling continues, add sufficient additional oil through the exhaust port until burbling ceases.

III-3. SHAFT SEAL REPLACEMENT.

To replace the shaft seal of a pump, drain the oil and remove the pump pulley and key. Remove the screws securing the old seal and pry it loose with a screwdriver or similar wedge, being careful not to mar the surface of the pump body against which the seal bits. Discard the seal and bits gasket. Inspect all surfaces and repair any damages with a fine abrasive stone. Wipe all sealing areas clean and place a film of DuoSeal oil on both the shaft and the inside bore of the new shaft seal. Using a new gasket, carefully slide the new seal into position and center it on the shaft. It is not necessary to apply any sealant to the gasket. Tighten the mounting screws uniformly and refill the pump with DuoSeal oil. Follow Instructions Included in repair kit.

III-4. REPAIRING OIL LEAKS.

III-4a. Location, Cause and Effect.

Oil leaks may develop wherever two mating faces are sealed with a gasket. Such seams may fail as the result of deterioration of the gasket material, loosening of the screws caused by temperature variations, or improper care as the result of previous reassembly. Typical gasketed seams in a mechanical pump are located at the oil level window, the shaft seal, the oil drain, and the mating faces of such mechanical surfaces as the intake chamber cover, the oil case, and the exhaust chamber cover. The importance of a gasketed seam is determined principally by its function. If it is a vacuum seal, the ultimate performance of the pump is dependent upon it. If it is an oil seal, the pump may be operated satisfactorily for some time without loss of function. Eventually, of course, a great loss of oil may cause harmful damage.

III-4b. Repairing Technique.

An oil seam may be sealed by any of several methods. When an O-ring is employed, the surfaces of the O-ring and its groove should be wiped clean. If the O-ring is not badly deformed or scratched it may be reused by sealing with a slight film of vacuum oil or vacuum grease. Thin composition gaskets are generally used for large irregularly shaped areas. A replacement joint of this type should be thoroughly cleaned of all previous gasket material and the mating surfaces cleaned of any nicks.

III-5. REPAIRING VACUUM LEAKS.

III-5a. Surface Preparation.

Good vacuum seals are an essential and important attribute of a good mechanical pump. A good seal is dependent upon the quality of the mating surfaces as well as the sealant and its preparation. The mating faces should be carefully inspected for any projections or foreign particles which might interfere with proper mating. Slight projections such as nicks and burrs are most easily removed by rubbing with a fine abrasive stone. The surfaces of the mating parts may be washed with a solvent such as acetone after which they must be thoroughly dried. If a gasket is required, a very thin coat of varnish should be applied to both faces before assembly.

III-5b. Temporary Repair.

Temporary vacuum repairs are often made by covering the known leak with an industrial sealant such as Glyptal or Leak Lock. Such a practice, however, is not recommended for seals of a permanent nature.

III-6. MAINTENANCE OF HELIUM TRANSFER PUMPS.

A helium transfer pump is especially constructed to provide a vacuum-tight storage space for helium gas within the oil reservoir as well as the internal passages of the pump itself. Consequently, the importance of vacuum seals throughout the pump is increased, especially between the mating face of the oil case and the pump body. Instructions for the preparation of a gasketed vacuum seal are given in Paragraph III-5a. Equal care must also be applied to other areas such as the connection of the exhaust fitting and the oil level window, each of which must be vacuum tight.

III-7. DRIVE PROBLEMS.

If for any reason the pump will not operate, turn off the power and check the fuse and electrical connections. Then try the power to the motor only by removing the belt. If the motor operates properly try handrotating the pump in the proper direction with the pump intake port open. If both turn freely then replace the belt and check the belt tension. The tension should be just sufficient to drive the pump without visible slippage. Any greater tension will cause noise and possible damage to the bearings of both the motor and pump. Make certain that both pulley grooves are clean and free from oil. The pulleys must be fastened securely on their respective shafts, and in parallel alignment.

WARRANTY

This Sargent-Welch Vacuum Product is warranted to be free from defects in material and workmanship. The liability of Sargent-Welch Scientific Company under this warranty is limited to servicing, adjusting, repairing or replacing any unit or component part which in the judgment of Sargent-Welch Scientific Company has not been misused, abused or altered in any way or damaged by ingestion of foreign material causing impaired performance or rendering it inoperative.

The warranty is effective for one year from the date of original purchase when

- 1 The warranty card has been completed and returned
- 2 The product is returned to the factory or other designated service centers, prepaid
- 3 The product in our judgment is defective through no action or fault of the user

If the product has become defective through misuse, abuse, alteration or ingestion of foreign material, repairs will be billed regardless of the age of the product. In this event, an estimate of the repair costs will be submitted and authorization of these charges will be required before the product is repaired and returned.

Motors supplied with pumps are guaranteed by the motor manufacturer for one year. While the Company guarantees the complete unit, if a malfunction of the motor occurs, the motor manufacturer's local service branch should be contacted for immediate repair or replacement.

IV. SERVICE Repair and Exchange

For All Duo-Seal, DirecTorr and SarVac Pump Owners

What is the Exchange Pump Services When your DuoSeal or DirecTorr Vacuum Pump becomes inoperable you have three options avails able to you-

- 1 Buy a new pump
- 2 Have your pump repaired and returned
- 3 Use the Sargent-Welch Exchange Pump Service

How does the Exchange Pump Service work? To take advantage of this service (lower In cost than a new pump-quicker than pump repair), purchase an Exchange pump by specifying the model number of your pump requiring replacement The Exchange pump will be shipped from stock Mount a DuoSeal on your base and motor and resume operation DirecTorr pumps are shipped complete

Return your old pump to us In the same shipping crate for trade-in credit consideration

Exchange pumps are billed at the full last price of a new pump at the time of shipment Upon our receipt of your old pump of like model at the factory, a credit memorandum will be Issued to you, covering the exchange allowance for your pump, If it Is In repairable condition This memorandum may then be applied to the billed charge for the exchange pump

Repair Service for DuoSeal and DirecTorr, plus SarVac, pumps is available for customers who can spare their pump and want to have it repaired at a Sargent-Welch Service Center

All returned pumps are evaluated and repaired promptly by well qualified, Sargent-Welch factory trained personnel If the evaluation indicates that it Is not economical to repair the pump, the owners immediately notified Ail repaired pumps are returned with a factory warranty

Remember to use Sargent-Welch Service Centers for dependable quality service and supplies for your pump Gasket Kits, Repair Kits, genuine factory parts and other supplies are stocked for your routines maintenance needs

Both the Exchange Pump and Re. pair Services are available at three locations:

- 1 SKOKIE Main Factory at 7300 North Linder Avenue, Skokie, Illinois 60077
- 2 ANAHEIM at 1617 East Ball Roar', Anaheim, California 92803
- 3 SPRINGFIELD at 35 Stern Avenue, Springfield, New Jersey 07081

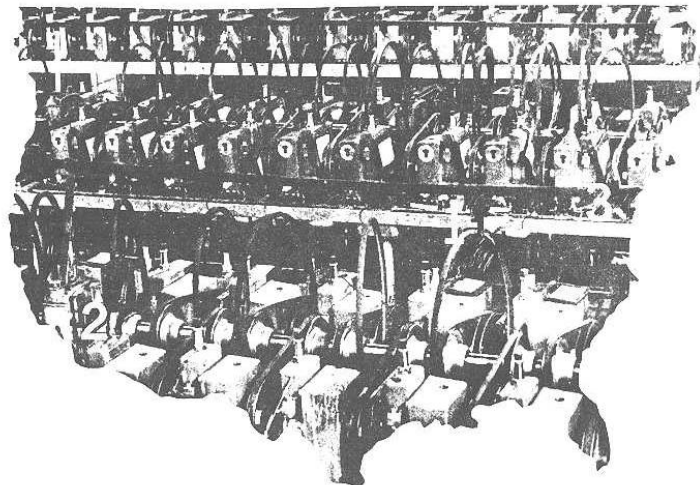

V. ACCESSORIES

Thermocouple Vacuum Gauges Two Models



1516 3-station, Thermocouple Vacuum Gauge with one permanently attached cable, one gauge tube and two quick-connect stations. 115 volt A.C., 0-1000 micron range.



1515 Single-station, Thermocouple Vacuum Gauge with one permanently attached cable and one gauge tube. 115 volt A.C., 0-5000 micron

Quick Disconnect Coupling Assemblies



CONNECTING UNION (NUT)
INTAKE TUBE
SQUEEZE WASHER
RUBBER O-RING
INTAKE COUPLING WITH A1 GASKET ATTACHES TO PUMP



DuoSeal Pump Oil

It is available in the sizes and quantities listed below and may be ordered by specifying Cat. No. 1407K and the quantity needed.

12 Quart Case 5 Gallon Drum
4 Gallon Case 55 Gallon Drum



1 qt. 1 gallon 5 gallons 55 gallons



Cat No.	For Pump Series	Specifications (inches)
1393A	1392, 1399, 1400, 1410	1/2 O.D. intake tube 1-1/4 dia. x 3-1/8 high, 3/8-18 straight thread.
1393B	1405	5/8 O.D. intake tube, 1-1/2 dia. x 3-1/8 high, 3/4-20 male thread.
1393C	1380, 1402	7/8 O.D. intake tube, 1-1/2 dia. x 3-5/8 high, 1-20 male thread.
1393D	1374, 1397	1-3/4 O.D. intake tube, 3 dia. x 5 high, 1-3/4-20 male thread.
1393E	1373, 1376	1-3/4 O.D. intake tube, 3 dia. x 5 high, 1-1/2-12 male thread.

Exhaust Filters

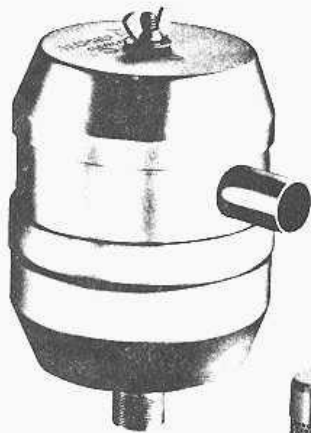

Cat. No.	For Pump Series	Specifications (inches)
1417	1392, 1399, 1400, 1405, 1410	2-1/2 dia. 2-3/8 high, 3/4-20 male thread
1417A	1376, 1380, 1402	5 dia. x 6-1/4 high 1-20 male thread.
1417B	1374, 1397	6-1/2 dia. 8-7/8 high, 1-3/4-20 male thread.
1417P	8806, 8811, 8816	2-1/2 dia. 3-3/8 high, 1-20 male thread.
1417S		1417A with adapter, 1-3/4-20 male thread.
1417T	1373	1417A with adapter, 1-20 male thread.
41-1746	1396	10-5/8 dia. x 9-1/4 high.
	1375, 1395, 1398	10-5/8 dia. x 7-3/4 high.

Replacement Elements

Cat. No.	For Exhaust Filter No.
1417L	1417
1417G	1417A
1417H	1417B
1417Q	1417P
41-1747	41-1746

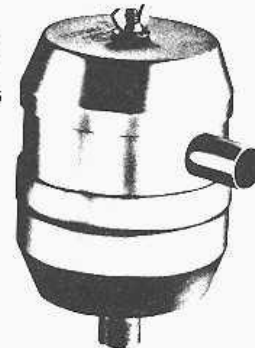

Sargent-Welch Vacuum Pump Cart

The Sargent-Welch Vacuum Pump Cart is designed and constructed for heavy-duty transportation of Sargent-Welch vacuum pumps and other materials. It can accommodate loads in excess of 500 pounds.

The cart is supplied with a thick-ribbed rubber mat, engineered to absorb sound and vibration and to

prevent slipping and sliding. Both shelves and legs are double-welded to insure squareness and durability. The cart's four sturdy free-rolling 4-inch rubber casters (2 with locks) are equipped with permanent shimmy dampeners. Dimensions are 18" x 24" x 16" high, and there is a 7½" clearance between the two shelves. When ordering, specify Cat. No. 1415A.

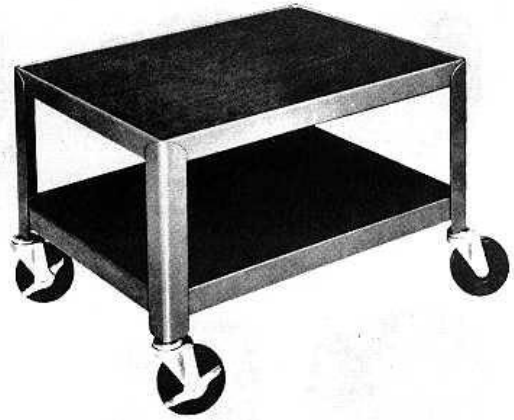

Tubing Clamps

This clamp exerts a uniformly distributed holding force completely around the circumference of the tubing. A wrench or screw driver is not needed for adjustment or tightening. The worm-type, self-locking screw gives uniform, instant adjustment. Six of one size in a package.

Cat. No.	For O.D. Size Tubing (inches)
4912	9/16 to 3/4
4912A	11/16 to 1-1/16
4912B	15/16 to 1-1/2
4912C	1-1/2 to 2-1/4
4912D	2-1/2 to 3-1/4



Vacuum Rubber Tubing

The tubing to be used in a vacuum system should be chosen with great care, even though the lengths ordinarily used may be short. This tubing is of high-grade, pure gum, red rubber, especially selected for its very low vapor pressure, uniformity of wall thickness, and excellent sealing properties. It is flexible, yet the extra-heavy wall is rigid enough to avoid collapsing under vacuum.

Cat. No.	I.D. (inches)	Wall (inches)
S-73590C	3/16	3/16
S-73590D	1/4	3/16
S-73590G	7/16	5/16
S-73590H	5/8	3/8
S-73590J	13/16	3/8
S-73590L	1-5/8	1/2

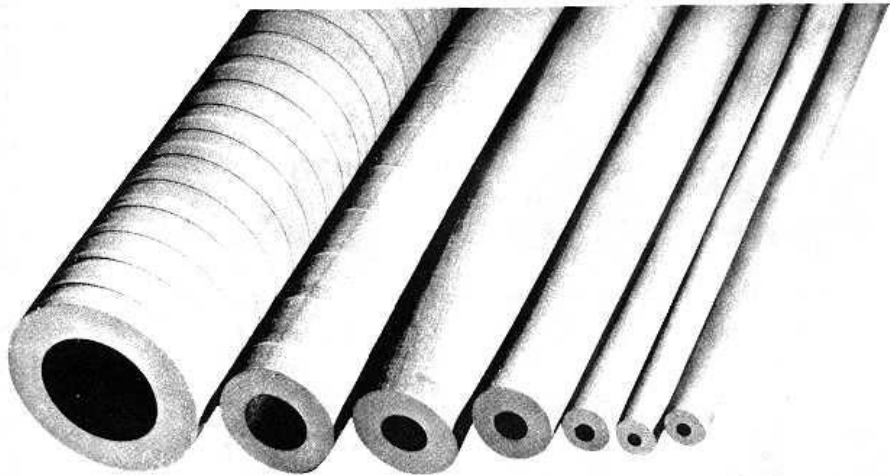

Belt Guard & Base Kits

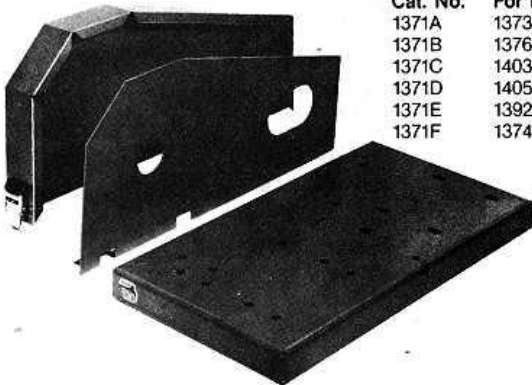

Cat. No.	For Pump Series
1371A	1373, 1380, 1402
1371B	1376
1371C	1403
1371D	1405
1371E	1392, 1399, 1400, 1410
1371F	1374, 1397

Belt Replacements

These are the same high quality V-belts that are originally supplied on DuoSeal Pumps.

Cat. No.	For Pump Series
1400A	1392, 1400, 1410
1405A	1373, 1376, 1380, 1402, 1403, 1405
1406A	1404
1399A	1399
1397A	1397
1374A	1374
41-1716	1375
41-2512	1395, 1396, 1398

Sargent-Welch Scientific Company

7300 North Linder Avenue
PO Box 1026
Skokie, Illinois 60077
(312) 677-0600

International Division

7300 North Linder Avenue
PO Box 1026
Skokie, Illinois 60077
(312) 677-0600

Anaheim, California

1617 East Ball Road
P O Box 4030
Anaheim, California 92803
(714) 772-3550

Birmingham, Alabama

3125 Seventh Avenue, North
PO Box 10404
Birmingham, Alabama 35202
(205) 251-5125

Cleveland, Ohio

9520 Midwest Avenue
Garfield Heights
Cleveland, Ohio 44125
(216) 587-3300

Dallas, Texas

3403 Century Circle
PO Box 152008
Irving, Texas 75015-2008
(214) 579-9200

Denver, Colorado

4040 Dahlia Street
PO Box 7196
Denver, Colorado 80207
(303) 399-8220

Detroit, Michigan

27501 School craft Road
Livonia, Michigan 48150
(313) 425-9400

Springfield, New Jersey

35 Stern Avenue
Springfield, New Jersey 07081
(201) 376-7050

Washington, D.C.

8401 Helgerman Court
Gaithersburg, Maryland 20877
(301) 948-2844

Toronto, Canada

285 Garyray Drive
Weston, Ontario M9L 1P3
(416) 741-5210

Montreal, Canada

3300 Cavendish Boulevard
Montreal PQ H4B 2M8
(514) 481-0119

Calgary, Canada

4220 23rd Street, N.E.
Bay No 12
Calgary, Alberta T2E 6X7
(403)

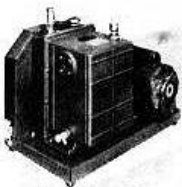

MODEL 1402B-15
1 x 10⁻⁴ Torr
160 1pm (5.6 cfm)

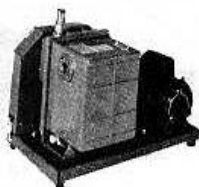

MODEL 1380
1.5 x 10⁻² Torr
160 1pm (3.5 cfm)

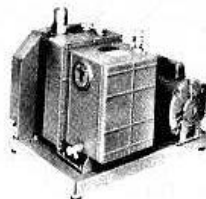

MODEL 1376B
1 x 10⁻⁴ Torr
300 1pm (10.6 cfm)

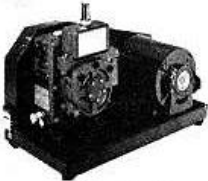

MODEL 1400B-15
1 x 10⁻⁴ Torr
25 1pm (0.9 cfm)



MODEL 1374
1 x 10⁻⁴ Torr
650 1pm (23 cfm)

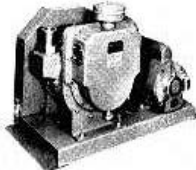

MODEL 1397B
1 x 10⁻⁴ Torr
500 1pm (17.7 cfm)



MODEL 1399
1.5 x 10⁻² Torr
35 1pm (1.2 cfm)



MODEL 1375
1 x 10⁻⁴ Torr
1000 1pm (35 cfm)



MODEL 1395
1 x 10⁻⁴ Torr
2000 1pm (71 cfm)

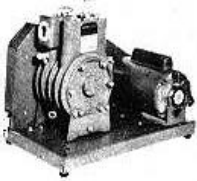

MODEL 1405
1 x 10⁻⁴ Torr
60 1pm (2.1 cfm)

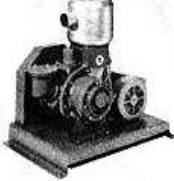

MODEL 1398M
1 x 10⁻⁴ Torr
1500 1pm (53 cfm)



MODEL 1396
1 x 10⁻⁴ Torr
2800 1pm (100 cfm)

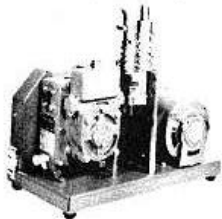

MODEL 1392
1 x 10⁻⁴ Torr
25 1pm (0.9 cfm)

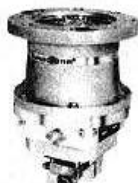

MODEL 3133
1 x 10⁻⁴ Torr
1500 1ps

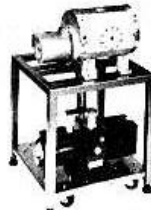

MODEL 3120D
1 x 10⁻² Torr
160 1ps



MODEL 8811
1 x 10⁻⁴ Torr
100 1pm (3.5 cfm)



MODEL 8803—Single-Stage
25 x 10⁻² Torr
25 1pm (0.9 cfm)



MODEL 8804B—Two-Stage
1 x 10⁻² Torr
25 1pm (0.9 cfm)

**APPENDIX A
REFERENCES**

A-1. **Scope.** This appendix contains all forms, pamphlets and technical manuals referenced in both the Air mobile and Semitrailer mounted Laboratories.

A-2. Forms.

Recommended Changes to Publications.....	DA Form 2028
.....	DA Form 2028-2
Quality Deficiency Report	SF 368
Equipment Inspection and Maintenance Work Sheet	DA Form 2404
Hand Receipts	DA Form 2062

A-3 Field Manuals

Petroleum Testing Facilities Laboratories and Kits	FM 10-72
Inspecting and Testing Petroleum Products	FM 10-70
ASTM Test Method Supplement to	FM 10-92C1/C2

A-4. Technical Manuals

Atlas-Copco Compressor	TM 10-4310-392-13&P
Alcor Jet Fuel Thermal Oxidation Tester Operating and Maintenance Manual	TM 10-6635-210-13&P
Bacharach Gas Alarm and Calibration Data	TM 104665-297-13&P
Brother Portable Typewriter	TM 10-7430-218-13&P
Chemtrix Field Ph Meter	TM 10-6630-237-13&P
Elkay Manufacturing 30 GPH Cooler	TM 10-4130-240-13&P
Emcee Micro-Separometer	TM 104640-222-13&P
Foxboro Pressure Recording Gauge	TM 104685-365-13&P
Gammon Aqua Glo Water Detector	TM 104640-221-13&P
Gammon Mini Monitor Fuel Sampling Kit	TM 104630-230-13&P
Jelrus Burn-Out Furnace	TM 104640-231-13&P
Koehler Cleveland Open Tester	TM 104630-236-13&P
Koehler Cloud and Pour Point Chamber	TM 104630-238-13&P
Koehler Copper Strip Corrosion Bomb Bath	TM 104640-220-13&P
Koehler Distillation Apparatus	TM 104630-233-13&P
Koehler Dropping Point Apparatus	TM 104635-211-13&P
Koehler Electric Pensky-Martins Tester	TM 104630-231 -13&P
Koehler Foaming Characteristics Determination Apparatus.....	TM 104640-228-13&P
Koehler Kinematic Viscosity Bath	TM 104630-239-13&P
Koehler Tag Closed Cup Flash Tester	TM 104630-235-13&P
Lab-Line Explosion Proof Refrigerator	TM 104640-219-13&P
Lily Freezer	TM 10-6640-234-13&P
Millipore OM 39 Filter Holder	TM 104640-225-13&P
Millipore Vacuum Pump	TM 104640-217-13&P
Ohaus Harvard Trip Balance	TM 104670-278-13&P
Precision Gas-Oil Distillation Test Equipment	TM 10-6630-219-13&P
Precision General Purpose Water Bath.....	TM 10-6640-229-13&P

Precision High Temperature Bronze Block Gum Bath	TM 10-6630-234-13&P
Precision General Purpose Ovens	TM 10-6640-218-13&P
Precision Heater Instruction Manual and Parts List	TM 10-640-223-13&P
Precision Oxidation Stability Bath	TM 10-640-232-13&P
Precision Pensky-Martens Flash Testers	TM 10-6630-231-13&P
Precision Reid Vapor Pressure Bath	TM 10-6640-226-13&P
Precision Slo-Speed Stirrer	TM 10-640-224-13&P
Precision Universal Centrifuge	TM 10-6640-230-13&P
Precision Universal Penetrometer	TM 10-6640-228-13&P
Sargent-Welch Vacuum Pump	TM 10-4310-391-13&P
Sartorius Analytical Balance	TM 10-6670-277-13&P
Scotsman Cuber	TM 10-6640-227-13&P
Soltec VOM-Multimeter	TM 10-6625-3127-13&P
Teel Self-Priming Centrifugal Pump	TM 10-640-217-13&P
Teel Submersible Pump	TM 10-4320-320-13&P
Texas Instrument TI-503011 Calculator	TM 10-7420-210-13&P

A-5. Pamphlets.

The Army Maintenance Management System (TAMMS)	DA Pam 738-750
--	----------------

A -6 . Miscellaneous Publications.

The Army Integrated Publishing and Panting Program	AR 25-30
Laboratory, Airmobile, Aviation Fuel	MIL-L-52733A(ME)
Apparatus, Instruments, Chemicals, Furniture, and Supplies for Industrial, Clinical, College and Government Laboratories	fisher Scientific Laboratories Catalog
Petroleum-Petrochemical Testing Equipment	Precision Scientific Catalog

APPENDIX B

MAINTENANCE ALLOCATION CHART
SECTION I. INTRODUCTIONB-1. **General.**

a. This section provides a general explanation of all maintenance and repair functions authorized at various maintenance categories

b. The Maintenance Allocation Chart (MAC) In Section II designates overall authority and responsibility for the performance of maintenance functions on the identified end Item or component The application of the maintenance functions to the end Item or component will be consistent with the capacities and capabilities of the designated maintenance categories.

c Section III lists the tools and test equipment (both special tools and common tool sets) required for each maintenance function as referenced from Section II.

d Section IV contains supplemental instructions and explanatory notes for a particular maintenance function.

B-2. Maintenance Functions. Maintenance functions will be limited to and defined as follows

a. Inspect To determine the serviceability of an Item by comparing its physical, mechanical, and/or electrical characteristics with established standards through examination (e.g. by sight, sound, or feel)

b. Jest. To verify serviceability by measuring the mechanical, pneumatic, hydraulic, or electrical characteristics of an Item and comparing those characteristics with prescribed standards

c. Service. Operations required periodically to keep an Item In proper operating condition, i e., to clean (includes decontaminate, when required), to preserve, to drain, to paint, or to replenish fuel, lubricants, chemical fluids, or gases.

d. Adjust. To maintain or regulate, within prescribed limits, by bringing Into proper or exact position, or by setting the operating characteristics to specified parameters

e. Align. To adjust specified variable elements of an item to bring about optimum or desired performance

f Calibrate. To determine and cause corrections to be made or to be adjusted on Instruments or test, measuring, and diagnostic equipments used In precision measurement. Consists of comparisons of two Instruments, one of which is a certified standard of knob accuracy, to detect and adjust any discrepancy In the accuracy of the Instrument being compared

g. Remove/Install. To remove and install the same Item when required to perform service or other maintenance functions Install may be the act of emplacing, seating, or fixing Into position a spare, repair part, or module (component or assembly) in a manner to allow the proper functioning of an equipment or system.

h. Replace To remove an unserviceable Item and install a serviceable counterpart in its place "Replace" is authorized by the MAC and is shown as the third position code of the SMR code

i. Repair. The application of maintenance services,¹ including fault location/troubleshooting,² removal/installation and disassembly/assembly procedures³ end maintenance actions,⁴ to identify troubles and restore serviceability to an Item by correcting specific damage, fault, malfunctions, or failure in a part, subassembly, module (component or assembly), end Item, or system.

j. Overhaul. That maintenance effort (service/action) prescribed to restore an Item to a completely serviceable/operational condition as required by maintenance standards in appropriate technical publications (i.e. DMWR). Overhaul is normally the highest degree of maintenance performed by the Army. Overhaul does not normally return an Item to like-new condition.

k. Rebuild. Consists of those services/actions necessary for the restoration of unserviceable equipment to a like-new condition in accordance with original manufacturing standards. Rebuild is the highest degree of materiel maintenance applied to Army equipment. The rebuild operation includes the act of returning to zero those age measurements (hours/miles, etc) considered in classifying Army equipment/components.

B-3. Explanation Of Columns In The MAC, Section II.

a. Column 1. Group Number. Column 1 lists functional group code numbers, the purpose of which is to identify maintenance significant components, assemblies, subassemblies, and modules with the next higher assembly. End item group number shall be "00."

b. Column 2. Component/Assembly. Column 2 contains the names of components, assemblies, subassemblies, and modules for which maintenance is authorized.

c. Column 3 Maintenance Function. Column 3 lists the functions to be performed on the Item listed in column 2. (For a detailed explanation of these functions, see paragraph B-2.)

d. Column 4. Maintenance Category. Column 4 specifies, by the listing of a work time figure in the appropriate subcolumn(s), the category of maintenance authorized to perform the function listed in column 3. This figure represents the active time required to perform that maintenance function at the indicated category of maintenance. If the number or complexity of the tasks within the listed maintenance function vary at different maintenance categories, appropriate work time figures will be shown for each category. The work time figure represents the average time required to restore an item (assembly, subassembly, component, module, end item, or system) to a serviceable condition under typical field operating conditions. This time includes preparation time (including any necessary disassembly/ assembly time), troubleshooting/fault location time, and quality assurance/quality control time in addition to the time required to perform the specific tasks identified for the maintenance functions authorized in the maintenance allocation chart. The symbol designations for the various maintenance categories are as follows .

-
- 1 Services - Aspect, test, service, adjust, align, calibrate, and/or replace
 - 2 Fault locate/troubleshoot- the process of investigating and detecting the cause of equipment malfunctioning, the act of isolating a fault within a system or unit under test (UUT)
 - 3 Disassemble/assemble - encompasses the step-by-step taking apart (or breakdowns of a spare/functional group coded item to the level of its least commonality identified as maintenance significant (ie, assigned an SMR code) for the category of maintenance under consideration
 - 4 Actions - welding, grinding, riveting, straightening, facing, re-machining, and/or resurfacing

- C..... Operator/Crew
- O Unit Maintenance
- F Direct Support Maintenance
- H..... General Support Maintenance
- D Depot Maintenance

e. Column 5. Tools and Equipment Column 5 specifies, by code, those common tool sets (not individual tools) and special tools, TMDE, and support equipment required to perform the designated function.

f. Column 6. Remarks. This column shall, when applicable, contain a letter code, in alphabetic order, which shall be keyed to the remarks contained in section IV

B-4 Explanation Of Columns In Tool And Test Equipment Requirements, Section III .

a. Column 1 Reference Code The tool and test equipment reference code correlates with a code used in the MAC, section 11, column 5

b. Column 2. Maintenance Category. The lowest category of maintenance authorized to use the tool or test equipment

c. Column 3 Nomenclature. Name or identification of the tool or test equipment

d. Column 4 National Stock Number The National stock number of the tool or test equipment

e. Column 5 Tool Number The manufacturer's part number.

B-5. Explanation Of Columns In Remarks, Section IV .

a. Column 1 Reference Code The code recorded in column 6, Section II

b. Column 2. Remarks This column lists information pertinent to the maintenance function being performed as indicated in the MAC, section II.

Section II. MAINTENANCE ALLOCATION CHART

TM 11-5805-234-12

SECTION II MAINTENANCE ALLOCATION CHART (CONTINUED)

(1) GROUP NUMBER	(2) COMPONENT/ ASSEMBLY	(3) MAINTENANCE FUNCTION	(4) MAINTENANCE LEVEL					(5) TOOLS AND EQUIPMENT	(6) REMARKS
			C	O	F	H	D		
01	VACUUM PUMP SARGENT-WELCH	INSPECT SERVICE	0.2 0.3						
011	PUMPING ASSEMBLY	REPLACE REPAIR		1.0 1.0	4.0			1 1	A
012	MOTOR	REPLACE REPAIR		1.0 1.0	4.0			1 1,2,3	B

Section III. TOOL AND TEST EQUIPMENT REQUIREMENTS

FOR

MAINTENANCE ALLOCATION CHART

(1) TOOL/TEST EQUIP REF CODE	(2) MAINTENANCE CATEGORY	(3) NOMENCLATURE	(4) NSN	(5) TOOL NUMBER
1	O,F	TOOL KIT, GENERAL AUTOMOTIVE	5180-00-177- 7033	(50980) SC 5180-90- CL-N26
2	F	TOOL KIT, SHOP EQUIPMENT AUTOMOTIVE MAINTENANCE AND REPAIR, COMMON No 1 (LESS POWER)	4910-00-754- 0654	(19204) SC 4910-95- CL-A74
3	F	MULTIMETER, 0-500V	6625-00-691- 2453	

Section IV. REMARKS

REFERENCE CODE	REMARKS
A	REPAIR AT ORGANIZATION LIMITED TO REPLACEMENT OF PULLEY, EXHAUST CHAMBER, INTAKE CHAMBER, TENSION CHAMBER, VENTED EXHAUST VALVE, DRAIN VALVE, MOUNTING LEGS, AND ASSOCIATED HARDWARE AND GASKETS
B	REPAIR AT ORGANIZATION LIMITED TO REPLACEMENT OF BELT PULLEY, MOUNTING LEGS, BRUSHES, AND ASSOCIATED HARDWARE

**APPENDIX C
COMPONENTS OF END ITEM AND BASIC ISSUE ITEMS LISTS
NOT APPLICABLE**

C-1/ (C-2 blank)

**APPENDIX D
ADDITIONAL AUTHORIZATION LIST
NOT APPLICABLE**

**APPENDIX E
EXPENDABLE/DURABLE SUPPLIES AND MATERIALS LIST
Section I. INTRODUCTION**

E-1. **Scope.** This listing is for informational purposes only and is not authority to requisition the listed items. These items are authorized to you by CTA 50-970, Expendable/Durable Items (except medical, class V, repair parts, and heraldic items)

E-2. Explanation of Columns.

a. Column (1) - Item Number. This number is assigned to the entry in the listing and is referenced in the narrative instructions to identify the material (e.g. Use cleaning compound, item 5, appendix C)

b. Column (2) - Level This column identifies the lowest level of maintenance that requires the listed item

C - Operator/Crew O - Unit Maintenance F - Direct Support Maintenance H - General Support Maintenance

c. Column (3) - National Stock Number. This is the National stock number assigned to the item; use it to request or requisition the item.

d. Column (4) - Description Indicates the Federal item name, and, if required, a description to identify the item. The last line for each item indicates the Commercial and Government Entity Code (CAGEC) in parentheses followed by the part number

e. Column (5) - Unit of Measure (U/M). Indicates the measure used in performing the actual maintenance function. This measure is expressed by a two-character alphabetical abbreviation (e.g. EA, IN, PR). If the unit of measure differs from the unit of issue, requisition the lowest unit of issue that will satisfy your requirements.

Section II. EXPENDABLE/DURABLE SUPPLIES AND MATERIALS LIST

(1) Item Number	(2) Level	(3) National Stock Number	(4) Description	(5) U/M
			VACUUM OIL, "DUO SEAL" (64484) 1 407K	QT
			FILTER ELEMENT, (64484) 41-0891	EA

E-1/(E-2 Blank)

By Order of the Secretary of the Army:

CARL E. VUONO
General, United States Army
Chief of Staff

Official:

THOMAS F. SIKORA
Brigadier General, United States Army
The Adjutant General

DISTRIBUTION

To be distributed in accordance with DA Form 12-21A, Operator, Unit and Direct Support Maintenance requirements for Laboratory, Petroleum, MTD

The Metric System and Equivalents

Linear Measure

1 centimeter = 10 millimeters = .39 inch
 1 decimeter = 10 centimeters = 3.94 inches
 1 meter = 10 decimeters = 39.37 inches
 1 dekameter = 10 meters = 32.8 feet
 1 hectometer = 10 dekameters = 328.08 feet
 1 kilometer = 10 hectometers = 3,280.8 feet

Weights

1 centigram = 10 milligrams = .15 grain
 1 decigram = 10 centigrams = 1.54 grains
 1 gram = 10 decigrams = .035 ounce
 1 dekagram = 10 grams = .35 ounce
 1 hectogram = 10 dekagrams = 3.52 ounces
 1 kilogram = 10 hectograms = 2.2 pounds
 1 quintal = 100 kilograms = 220.46 pounds
 1 metric ton = 10 quintals = 1.1 short tons

Liquid Measure

1 centiliter = 10 milliliters = .34 fl. ounce
 1 deciliter = 10 centiliters = 3.38 fl. ounces
 1 liter = 10 deciliters = 33.81 fl. ounces
 1 dekaliter = 10 liters = 2.64 gallons
 1 hectoliter = 10 dekaliters = 26.42 gallons
 1 kiloliter = 10 hectoliters = 264.18 gallons

Square Measure

1 sq. centimeter = 100 sq. millimeters = .155 sq. inch
 1 sq. decimeter = 100 sq. centimeters = 15.5 sq. inches
 1 sq. meter (centare) = 100 sq. decimeters = 10.76 sq. feet
 1 sq. dekameter (are) = 100 sq. meters = 1,076.4 sq. feet
 1 sq. hectometer (hectare) = 100 sq. dekameters = 2.47 acres
 1 sq. kilometer = 100 sq. hectometers = .386 sq. mile

Cubic Measure

1 cu. centimeter = 1000 cu. millimeters = .06 cu. inch
 1 cu. decimeter = 1000 cu. centimeters = 61.02 cu. inches
 1 cu. meter = 1000 cu. decimeters = 35.31 cu. feet

Approximate Conversion Factors

To change	To	Multiply by	To change	To	Multiply by
inches	centimeters	2.540	ounce-inches	newton-meters	.007062
feet	meters	.305	centimeters	inches	.394
yards	meters	.914	meters	feet	3.280
miles	kilometers	1.609	meters	yards	1.094
square inches	square centimeters	6.451	kilometers	miles	.621
square feet	square meters	.093	square centimeters	square inches	.155
square yards	square meters	.836	square meters	square feet	10.764
square miles	square kilometers	2.590	square meters	square yards	1.196
acres	square hectometers	.405	square kilometers	square miles	.386
cubic feet	cubic meters	.028	square hectometers	acres	2.471
cubic yards	cubic meters	.765	cubic meters	cubic feet	35.315
fluid ounces	milliliters	29.573	cubic meters	cubic yards	1.308
pints	liters	.473	milliliters	fluid ounces	.034
quarts	liters	.946	liters	pints	2.113
gallons	liters	3.785	liters	quarts	1.057
ounces	grams	28.349	liters	gallons	.264
pounds	kilograms	.454	grams	ounces	.035
short tons	metric tons	.907	kilograms	pounds	2.205
pound-feet	newton-meters	1.356	metric tons	short tons	1.102
pound-inches	newton-meters	.11296			

Temperature (Exact)

°F	Fahrenheit temperature	5/9 (after subtracting 32)	Celsius temperature	°C
----	------------------------	----------------------------	---------------------	----

